

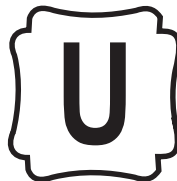

# **KTT-DS Series**

## **DIRECT STEAM TABLE TOP TILTING KETTLE INSTALLATION – OPERATION – MAINTENANCE**



**BLODGETT OVEN COMPANY**

[www.blodgett.com](http://www.blodgett.com)  
44 Lakeside Avenue, Burlington, Vermont 05401 USA Telephone (800) 331-5842, (802) 860-3700 Fax: (802) 864-0183

S00056 Rev A (5/04)

## **IMPORTANT NOTES FOR INSTALLATION AND OPERATION**

It is recommended that this manual be read thoroughly and that all instructions be followed carefully.



**This is the safety alert symbol. It is used to alert you to potential personal injury hazards. Obey all safety messages that follow this symbol to avoid possible injury or death.**



**WARNING: Improper installation, operation, adjustment, alteration, service or maintenance can cause property damage, injury or death. Read the installation, operating and maintenance instructions thoroughly before installing, operating or servicing this equipment.**

**This manual should be retained for future reference.**

**TABLE OF CONTENTS**

<b>DESCRIPTION</b>	<b>PAGE</b>
1.0 Service Connections .....	4
2.0 Introduction .....	5
3.0 Installation Instructions .....	6
4.0 Operating Procedures .....	7
5.0 Cleaning Procedures .....	8
6.0 Preventive Maintenance .....	8

# 1.0 SERVICE CONNECTIONS



STEAM SUPPLY: 1/2"IPS



CONDENSATE RETURN: 1/2"IPS

## DIMENSIONS

MODEL	CAPACITY	UNITS	A	B	C	D	E	F	G	H	J	K	L	M	N	O	P	Q
KTT-6DS	6 gallons	inches	12	14.5	19.5	13.75	5	7.5	15.12	8.5	12.25	10.38	30.25	4	4.38	34.12	0	15.75
	23 litres	mm	305	368	495	349	127	191	384	216	311	264	768	102	111	867	0	400
KTT-10DS	10 gallons	inches	16	15	18.5	13.75	7	7.75	19.12	9	16.25	8.88	32.25	2.38	4.88	33.12	0	15.75
	38 litres	mm	406	381	470	349	178	197	486	229	413	225	819	60	124	841	0	400
KTT-12DS	12 gallons	inches	16	17	20.5	13.75	7	7.75	19.12	9	16.25	10.88	39.5	2.38	4.88	35.12	0	15.75
	46 litres	mm	406	432	521	349	178	197	486	229	413	276	1003	60	124	892	0	400
KTT-20DS	20 gallons	inches	21	18	26.5	23.5	1.5	6.25	24.12	15.25	15.75	10.5	40.5	7.5	11.12	42.38	1.5	26
	76 litres	mm	533	457	673	597	38	159	613	387	400	267	1029	191	283	1076	38	660

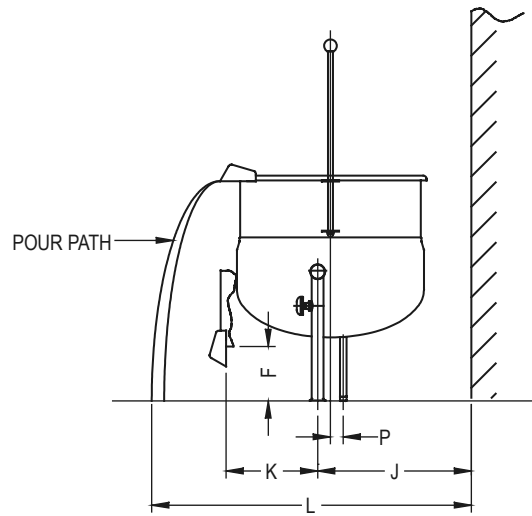
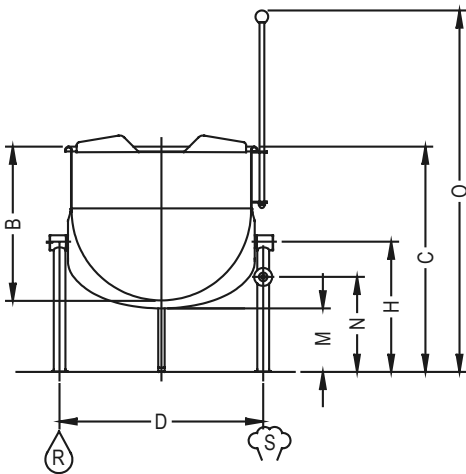
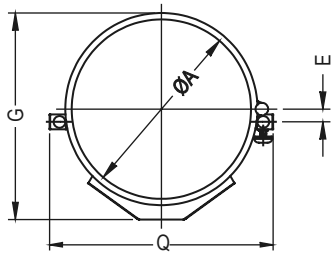

DIMENSIONS ARE IN INCHES [MM].

## **2.0 INTRODUCTION**

### **DESCRIPTION**

All direct connected steam jacketed kettles pertaining to this manual are direct steam operated pressure vessels of a double-wall stainless steel construction forming a steam chamber (jacket) enveloping the lower two thirds of the kettle bowl surface. All kettles are tilting and counter top mounted in fixed positions on legs.

### **CAPACITIES**

All models are suffixed with either -6, -10, 12 or -20 to indicated the capacity of that kettle in US gallons.

### **FUNCTIONING MODE**

Direct connected steam jacketed kettles consist of a stainless steel bowl and a stainless steel jacket which envelopes two thirds of the lower surface of the bowl thus forming a sealed pressure vessel (chamber) into which steam is introduced by means of a manual control valve.

The kettle bowl is the container for the food product which ideally should be of a liquid or semi-liquid consistency to achieve complete contact with the bowl surface and thus fully absorb the heat transmitted through that surface.

The temperatures required for the cooking process to function adequately must be greater than the boiling point of the liquid food product, viz. water. Further, the greater the steam pressure used, the higher the temperature and consequently the quicker the cooking process. For example, steam pressurized at 30 p.s.i. attains a temperature of 274 degrees Fahrenheit (135 degrees Celsius).

In the initial stages of the cooking process when the steam comes in contact with the cold kettle bowl surface it condenses and forms considerable amounts of water. A thermostatic steam trap should be plumbed to the exit end of the kettle jacket. This trap is a mechanical device that closes on high temperatures and opens when the temperature drops thus allowing the water formed from condensate to exhaust but retain steam under pressure.

### **3.0 INSTALLATION INSTRUCTIONS**

1. These kettles must be installed on a suitable table or counter top.
2. On counter top make 7/8" holes at 13 - 3/4" centers for kettle legs on Models KTT-6DS, KTT-10DS, KTT-12DS and 12, 23-1/2" centers on Model KTT-20DS. Provide sufficient space from rear wall to allow for tilting of kettle.
3. From bottom of stanchions remove mounting lockouts and washers. Apply Silastic to flared edge of stanchions. Insert threaded portion of stanchions through holes. Replace washers and locknuts and tighten. Wipe off excess sealant.
4. Install a safety relief valve in the steam line set at the maximum operating pressure of the kettle. Note that one valve will handle a series of kettles.
5. Connect steam supply line (1/2" pipe size) to steam inlet fitting on right stanchion.
6. Install a steam control valve in steam supply line, preferably near the kettle for ease of operation.
7. A pressure reducing valve will be required if the steam supply pressure is greater than the maximum kettle working pressure.
8. If large amounts of water are in the steam line it will be necessary to install one or more ball float traps in the line to eliminate the water.
9. A steam line pressure gauge is also recommended to determine the actual amount of steam coming to the kettle.
10. Install a suitable steam trap in condensate line (left stanchion) near the kettle and run condensate return line to drain. If the condensate return line will be directed to the boiler, then it must have a check valve and gate shut off valve near the kettle.

#### 4.0 OPERATING PROCEDURES



**CAUTION: THE APPLIANCE AND ITS PARTS ARE HOT. USE CARE WHEN OPERATING, CLEANING OR SERVICING THE APPLIANCE.**

1. Fill kettle with product to desired level.
2. Slowly turn the steam control valve ON to full open position.
3. The water or food should boil 3 - 4 minutes per gallon. If it does not, then incoming pressure should be checked to determine that it is adequate to operate the kettle efficiently.
4. Regulate steam control valve depending on type of food being prepared.
5. When food is cooked, turn off steam, remove food and clean kettle immediately to prevent residue from drying on kettle bowl surface.

## **5.0 CLEANING PROCEDURES**

Your kettle should be cleaned immediately after each use.

1. Ensure that steam supply is OFF.
2. Pre-rinse inside of kettle thoroughly and tilt to remove any food particles.
3. Using a nylon brush, clean kettle with a mild detergent and warm water rinse. Never use steel wool or scouring powder as it will scratch stainless steel.
4. Tilt kettle and rinse thoroughly draining out detergent solution.

### **WARNING**

**IT IS NOT RECOMMENDED TO USE CLEANING AGENTS THAT ARE CORROSIVE.**

Use of cleaning agents that contain chloride, acids or salts are corrosive and may cause pitting and corrosion when used over a period of time; this will reduce the life of the appliances.

Should pitting or corrosion occur this is not covered by warranty.

Follow the recommended cleaning instructions. Use a mild detergent, warm water and rinse thoroughly.

## **6.0 PREVENTIVE MAINTENANCE**

No preventive maintenance is required other than adhering to the Cleaning Procedure instructions.